

북천강석주(하동)

풀컬러색채선별기 구입 및 설치

[기준점 시설]

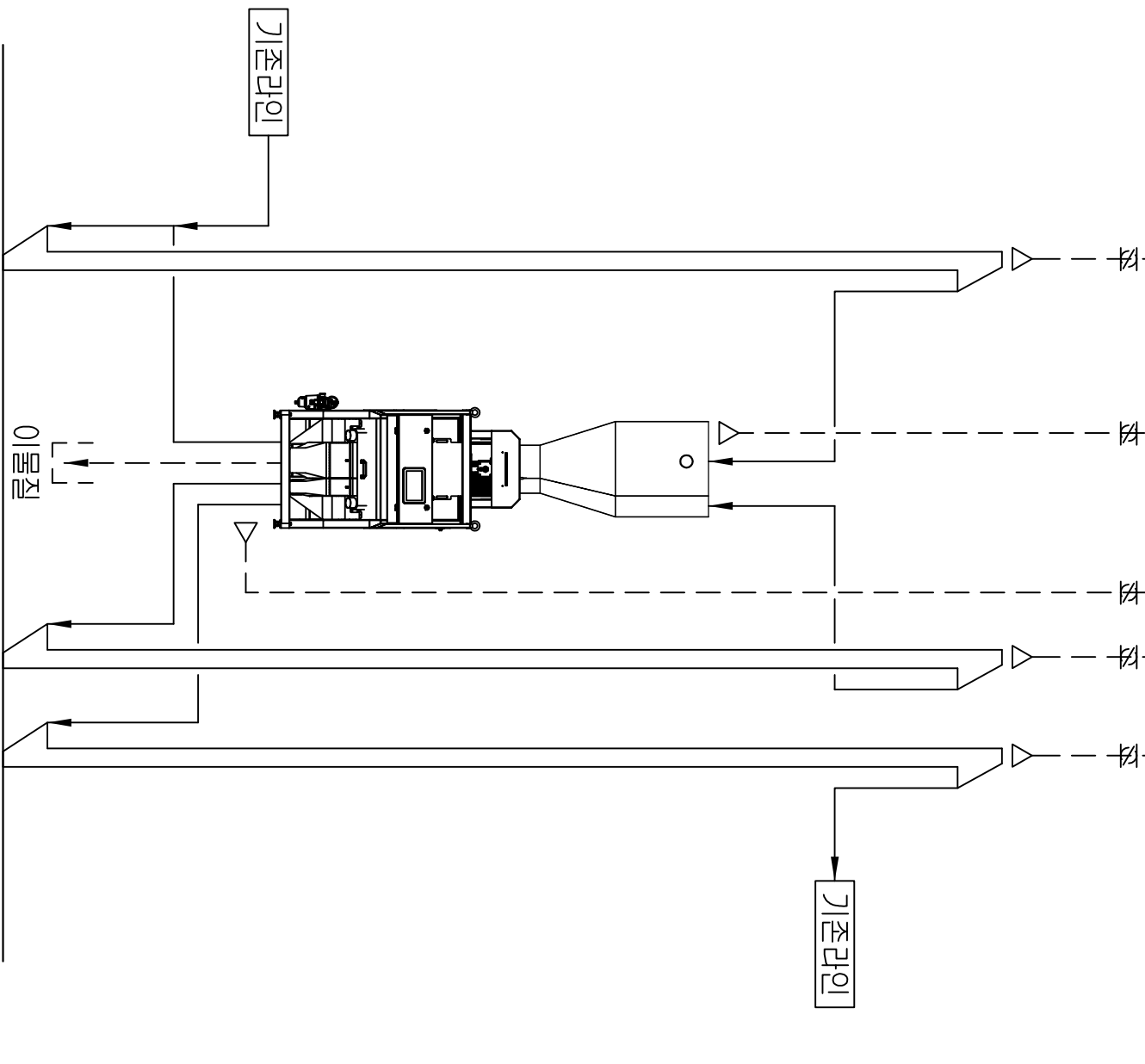

선택선별기

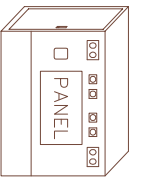
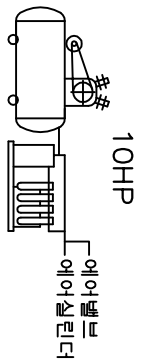

에어컴프레서

제어반

NO. 품번	DESCRIPTION 품명	MATERIAL 재질	QTY 수량	DIMENSION 규격	REMARKS 비고
APPD BY 승인인	UNIT 단위	MM . ###			
CHKD BY 검인인	SCALE 척도				
DSND BY 설계	PROJECTION 투영법		3	각	
DRWN BY 제	DATE 년월일				
REF. NO. 참고번호	TITLE 제		설치입면도		
DWG. NO. 도면번호			SHEET NO. OF	REV. 수정	

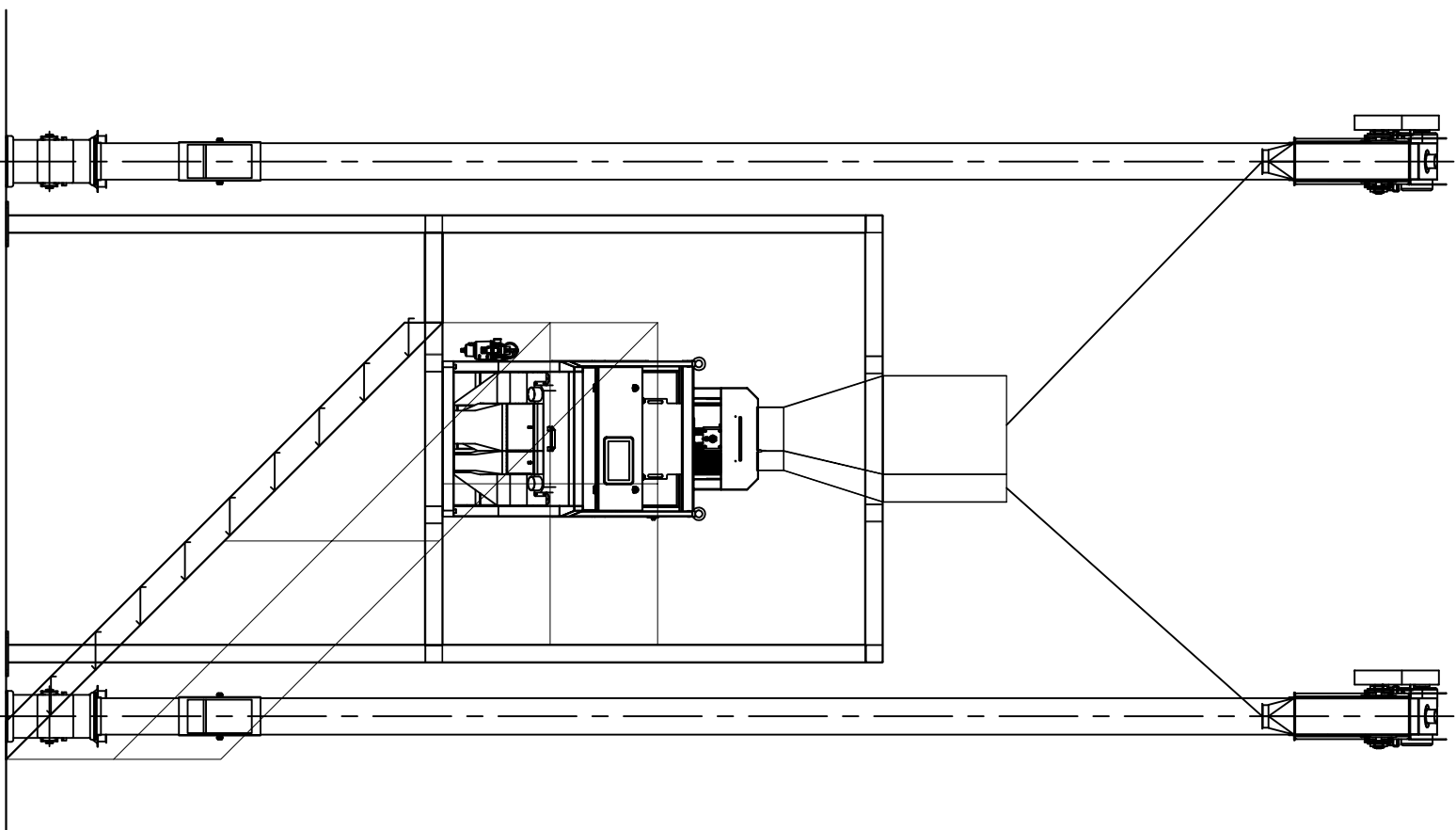

NO. 품번	DESCRIPTION 품명	MATERIAL 재료	QTY 수량	DIMENSION 규격	REMARKS 비고
APPD BY 승인인	UNIT 단위	MM . ###	PRO NAME 기계명	북진강역주(하동) 물류리색채선별기 구입 및 설치	
CHKD BY 검인도	SCALE 척도	1/40	TITLE 제목	설치입면도	
DSND BY 설도	PROJECTION 투영법	3 각 법	REF. NO. 참고번호	SHEET NO. OF	REV. 수정
DRWN BY 제도	DATE 년월일		DWG NO. 도면번호		

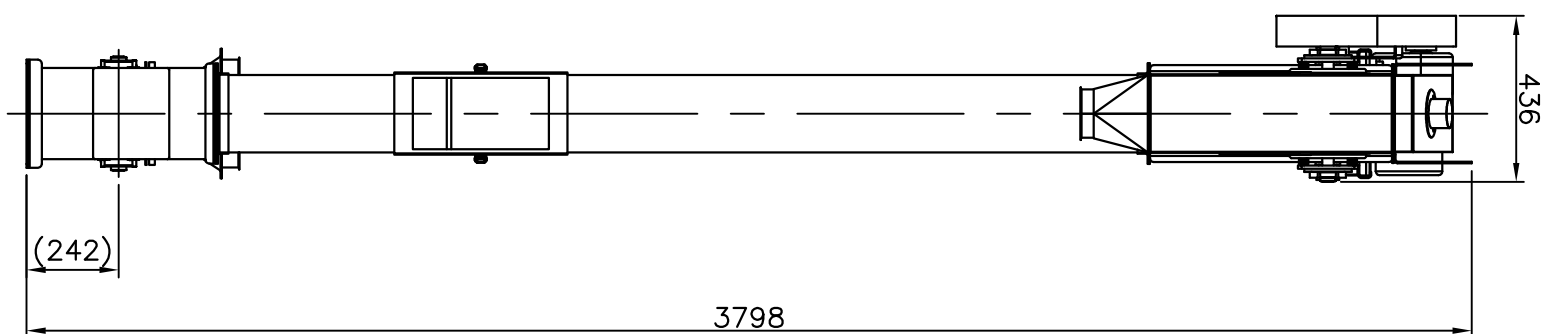
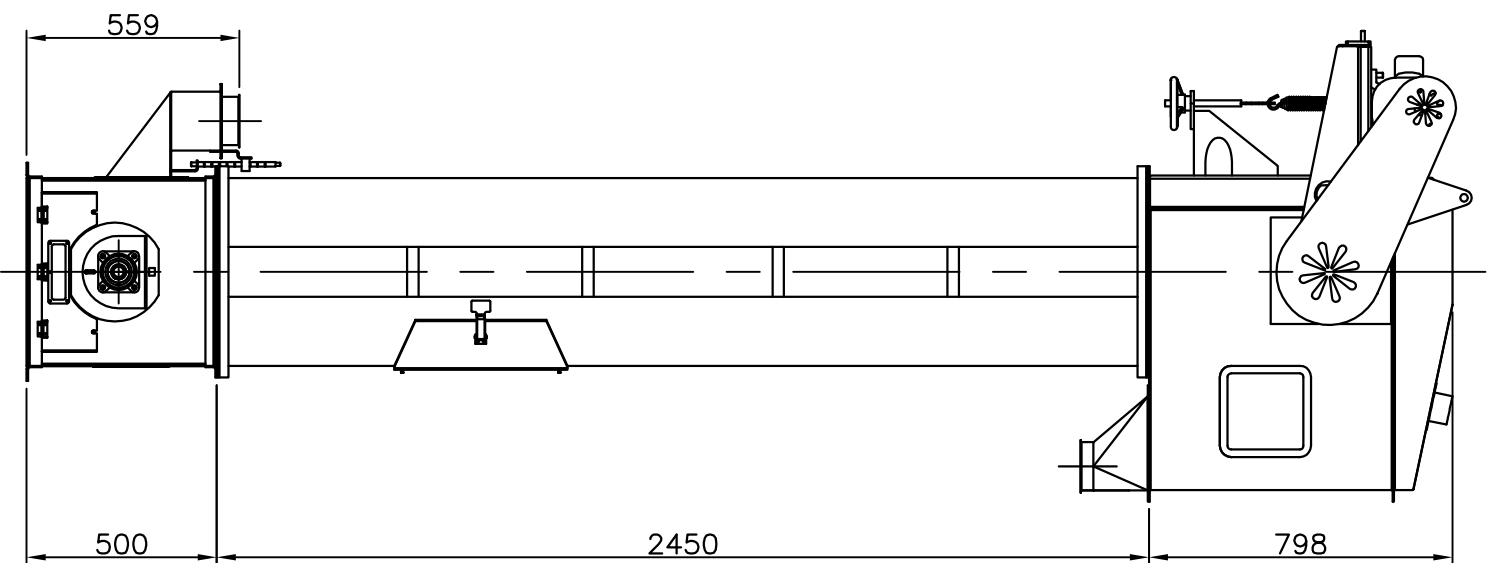

EF - 5NT SPECIFICATION	
TYPE	Sliding Discharge Type
CAPACITY	6.3 (ton/hr)
DRUM SIZE	200 (mm)
DRUM R.P.M	50 (R.P.M)
BUCKET SPEED	31.4 (m/min)
BUCKET SIZE	128 x 100 x 120
BUCKET VOLUME	0.000864 (m ³ /eo)
BUCKET PITCH	130 (mm)
GEARED MOTOR	1HP, 1/20, 4P
MOTOR SPROCKET	RS#60-16TB, Ø 32x10x89I
MAIN SPROCKET	RS#60-28TB, Ø 30x109I
HEAD BEARING	UCFC 206
TAIL BEARING	UCFL 206
BELT SIZE	150WXEP100X4P

- NOTE**
1. 몸통은 8지(2450mm), 6지(1850mm), 4지(1250mm), 2지(650mm) 기준으로 제작하여 조립한다.
 2. 몸통 중 8지(2450mm), 4지(1250mm) 이외품은 주문 사양임.
 3. 몸통 조립시 직진도(수직수평)를 ±5mm 이내로 할 것.
 4. 몸통 조립시 몸통사이에 패킹을 삽입하여 조립을 한다.

NO.	DESCRIPTION	MATERIAL	QTY	DIMENSION	REMARKS
APPD BY	중 인	UNIT	MM . ####	PRO NAME	북진강역주(아동)
CHKD BY	김 도	SCALE	1:20	기 계 명	물량리세렉선별기 구인 및 설치
DSND BY	김 계	PROJECTION	3 각 법	제 목	BUCKET ELEVATOR(EF-5NT)
DRWN BY	김 도	DATE		REF. NO.	
				중 고 번호	
				DWG. NO.	
				도면 번호	
				SHEET NO.	
				OF	
				REV.	
				수 정	

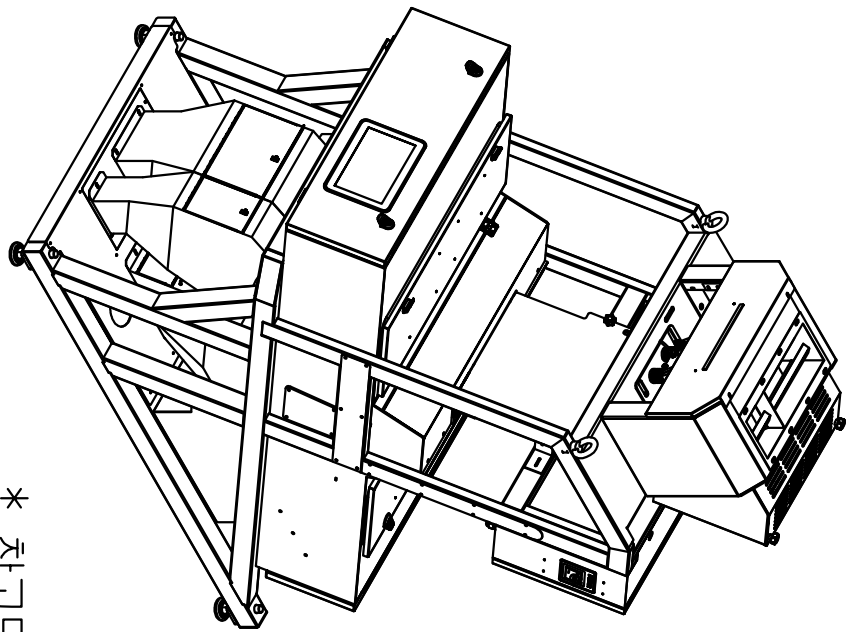
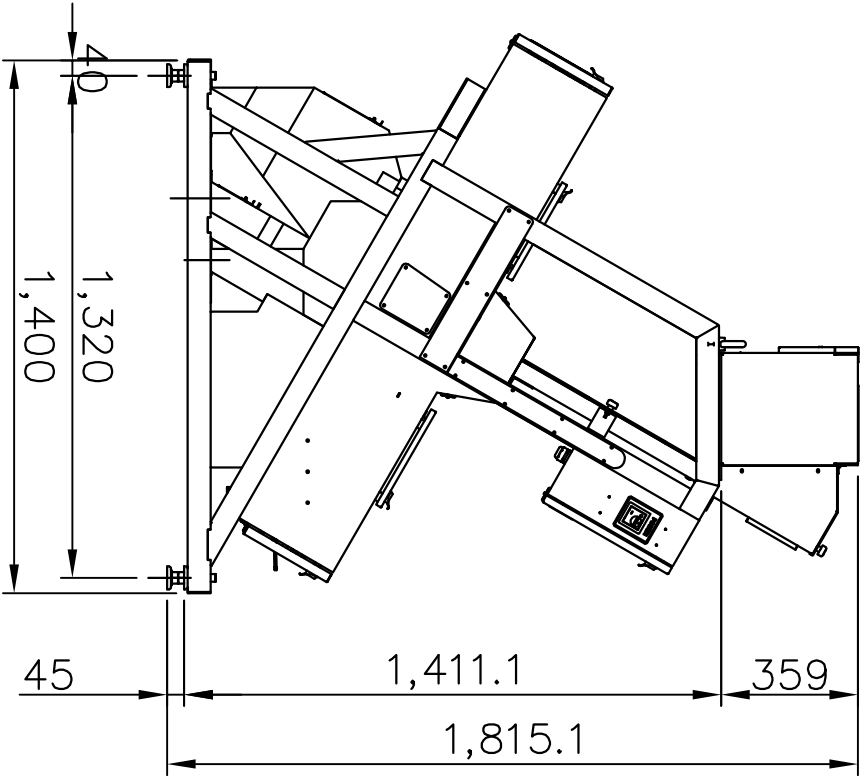
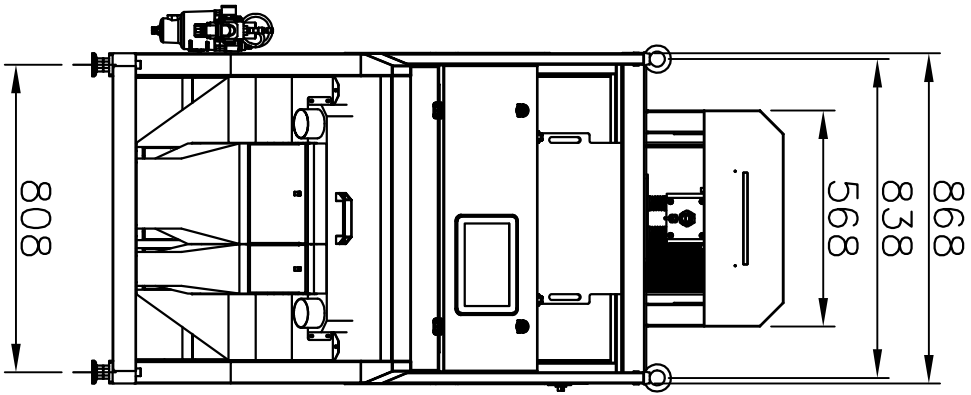
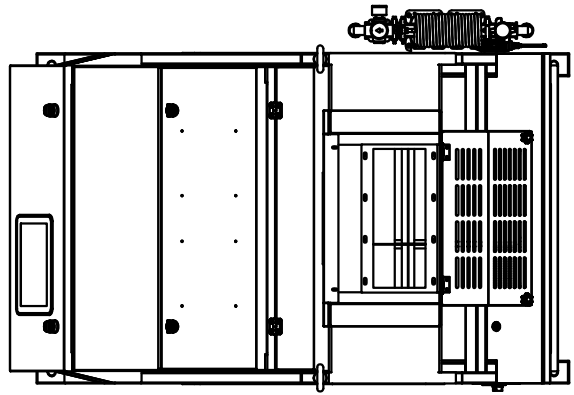

* 참고도

NO. 품번	DESCRIPTION 품명	MATERIAL 재료	QTY 수량	DIMENSION 규격	REMARKS 비고
APPD BY 승인인	UNIT 단위	MM . ####	PRO NAME 기계명	북진강색채선별기(이동)	
CHKD BY 검도인	SCALE 척도	1:20	TITLE 제목	북진강색채선별기 구입 및 설치	
DSND BY 설도인	PROJECTION 투영법	3 각 법	색채선별기		
DRWN BY 제도인	DATE 년월일		REF. NO. 참고번호	SHEET NO. OF	SHEET NO. OF
			DWG NO. 도면번호	REV. 수정	REV. 수정

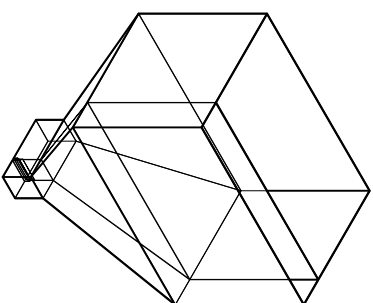
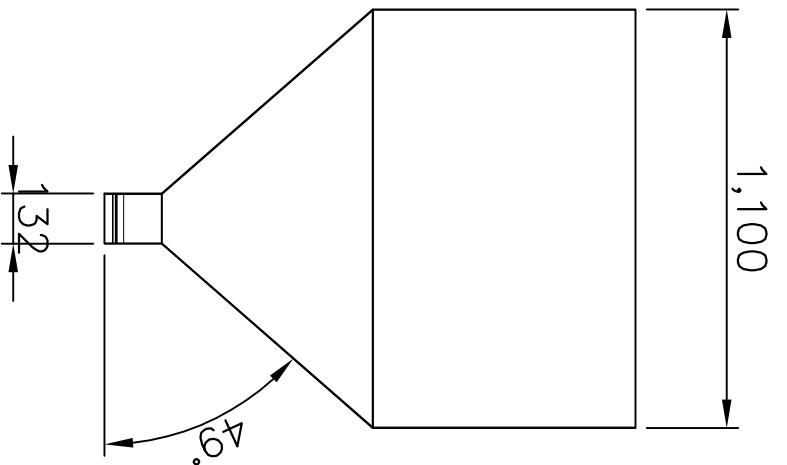
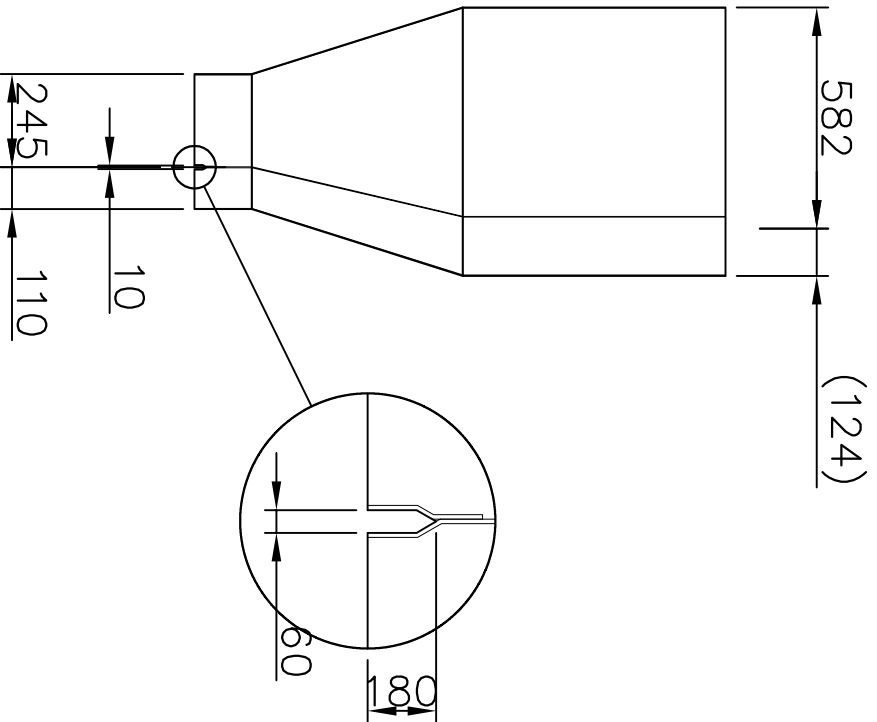
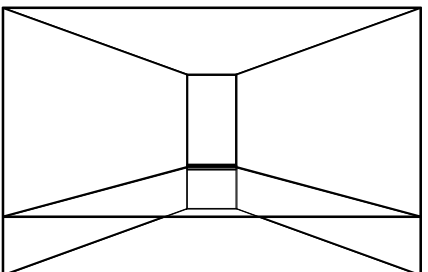

* 참고도

NO. 품번	DESCRIPTION 품명	MATERIAL 소재명	QTY 수량	DIMENSION 규격	REMARKS 비고
APPD BY 승인인	UNIT 단위	MM . ###	PRO NAME 기명	복원강역주(이동)	
CHKD BY 검도인	SCALE 척도	1:20	TITLE 제명	물류라색채선별기 구인 및 설치	
DSND BY 설도인	PROJECTION 투영법	3 각 법	REF. NO. 참고번호	SHEET NO. OF 수정	
DRWN BY 제도인	DATE 년월일		DWG NO. 도면번호	REV. 수정	
색채선별기 보조명규					

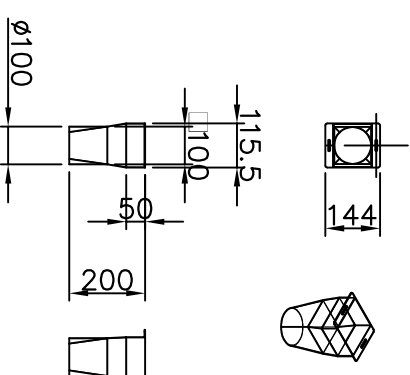
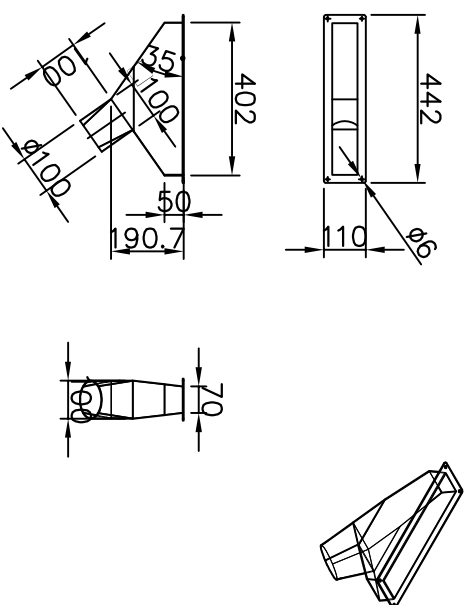
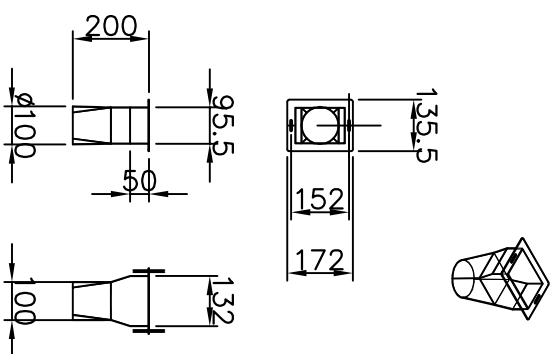
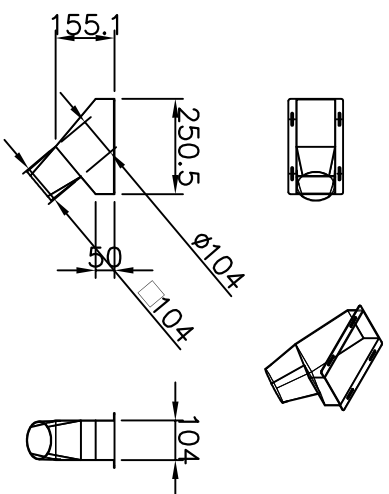
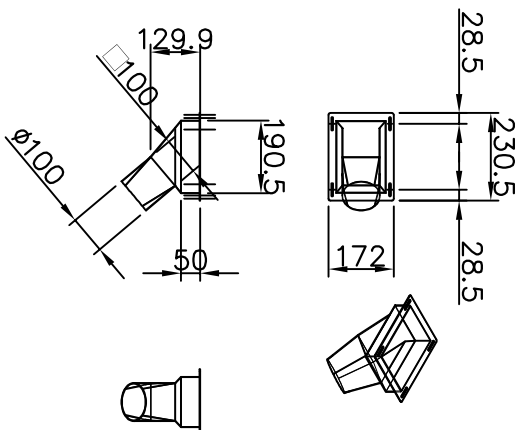

NO. 番 号	DESCRIPTION 説 明	MATERIAL 材 質	QTY 数 量	DIMENSION 寸 法	REMARKS 備 考
APPD BY 申 込 人	UNIT 単 位	MM . ###			
CHKD BY 検 査 人	SCALE 縮 尺	1:20			
DSND BY 送 付 者	PROJECTION 투영법	3 각 법			
DRWN BY 製 図 者	DATE 日 付				
	TITLE 題 名				
	REF. NO. 参 照 番 号				
	DWG. NO. 図 面 番 号				
	SHEET NO. シ ー ツ 番 号				
	REV. 修 正				

색채선별기 하부준퍼

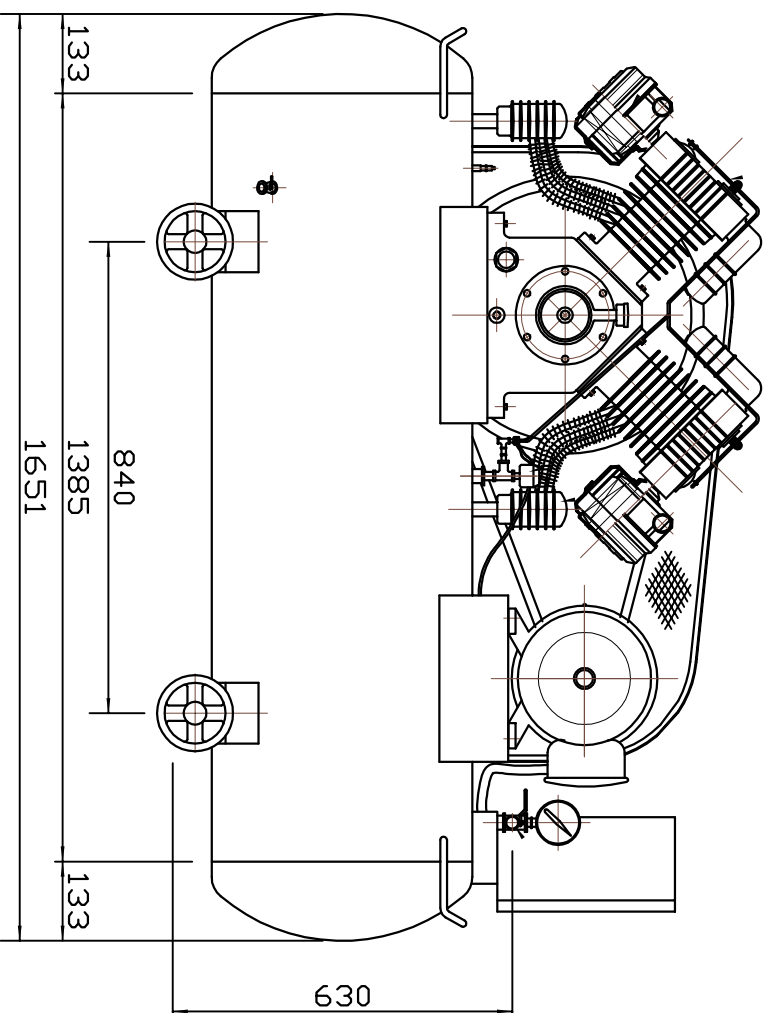
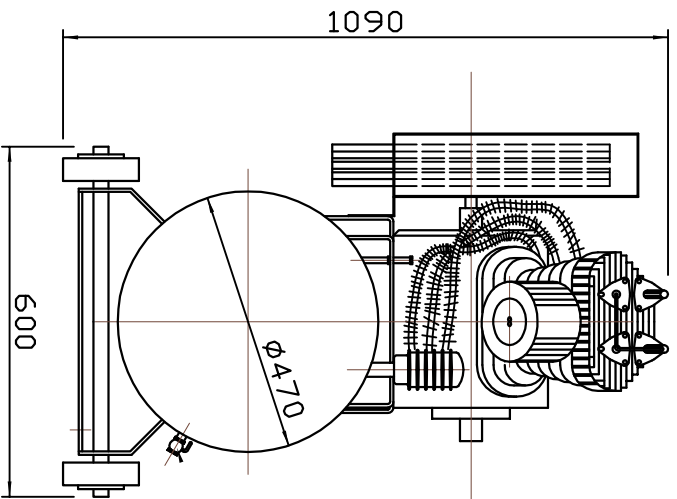

NO. 품번	DESCRIPTION 품명	MATERIAL 재질	QTY 수량	DIMENSION 규격	REMARKS 비고
APPD BY 승인	UNIT 단위	MM . ###	PRO NAME 기명	북진강역차(이동)	
CHKD BY 검도	SCALE 척도	1:20	TITLE 제목	물처리색전선별기 구입 및 설치	
DSND BY 설계	PROJECTION 투영법	3 각 법	REF. NO. 참고 번호	공포레서 외형도	
DRWN BY 제도	DATE 년월일		DWG NO. 도면 번호	SHEET NO. OF REV. 수정	